

Art of **P**recision & **P**erformance

# Vturn-NP16/NP20

New & Narrow Lathe with High Performance

- Machine width 1.5/1.93 meters (NP16/NP20)
- Turning length 250/400 mm (NP16/NP20)
- Rapid feeds 30/30 m/min
- Roller guideways
- Servo turret
- One-piece slant bed
- Rear / Right chip disposal
- Ready for unmanned operation



# Pursuit of Productivity

## New & Narrow Lathe NP16/NP20

- Machine width only 1488 mm / 1930 mm
- Z-travel 250 mm / 400 mm
- High rapid feed 30 m/min
- 6" / 8" power chuck
- Rear chip disposal



1488 mm (NP16)

1930 mm (NP20)

# Victor Taichung's own spindle

## NP16: Spindle output 11 kW (S3-15%)

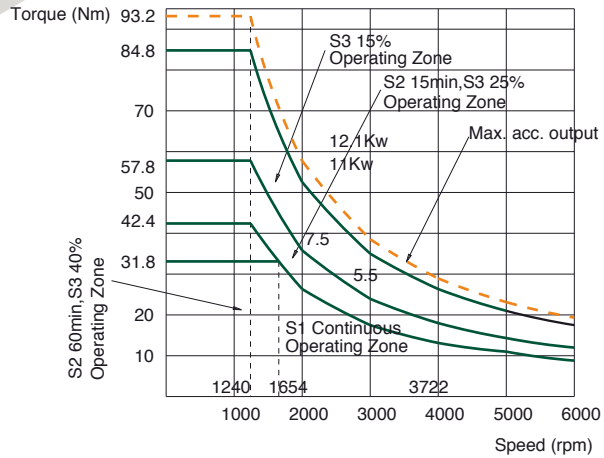
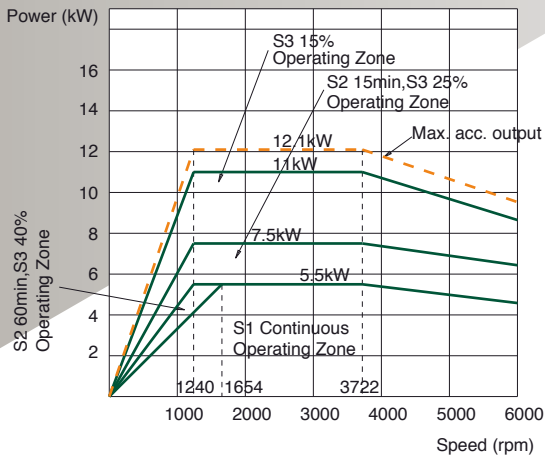

## NP20: Spindle output 15 kW (S3-15%)

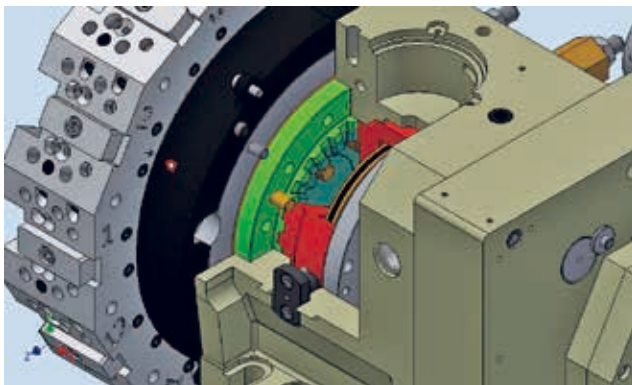
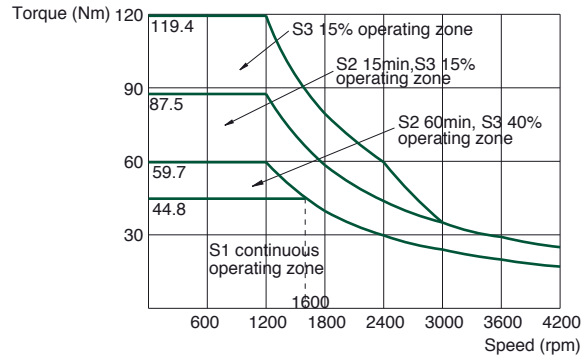
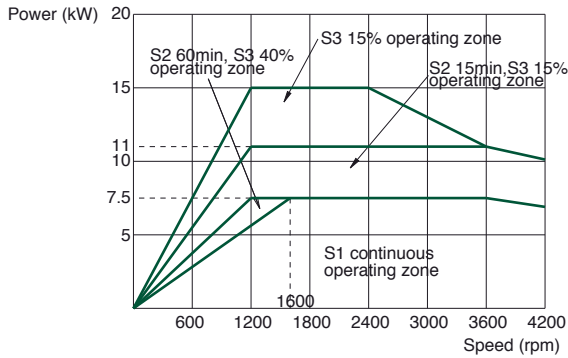

## Servo driven Turret

- 3-piece coupling design without turret disk up/down affords high pressure coolants without leakage during indexing.
- Turret indexing time 0.9 (T-T, opposite).
- C-axis option is available with BMT milling turret.



Certificated Casting

**GM400**  
**GA350**

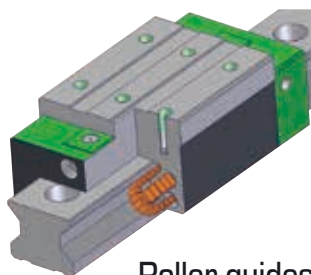

Roller guides

**35 mm (X/Z)**

## Strong structure

- One piece slant bed
- High rapid feeds 30/30 m/min
- Roller type guideways
- Meehanite casting

# Standard Accessories

## Fanuc 0i-TF (10.4") control + Manual Guide I (MGI)

- Right side for easy operation
- Manual Guide I for easy programming
- Inverter type hydraulic tank reduces the temperature rise



## Coolants & chips disposal

- Coolant flush on Z-axis covers.
- Cliff design minimizes chip built-up.
- Rear disposal chip conveyor minimizes machine width.



Fanuc 0i-TF (10.4")

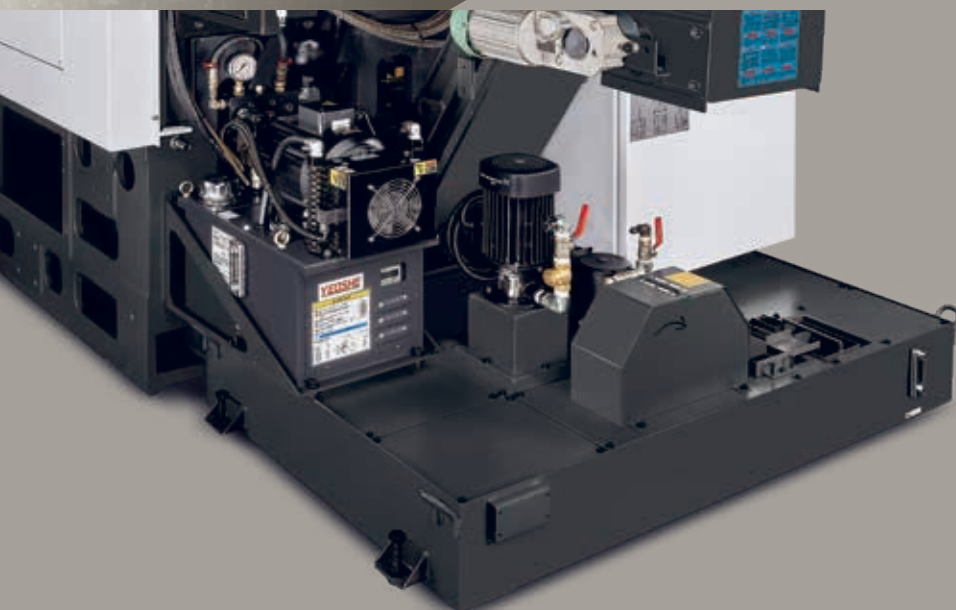

Oil skimmer (opt.)



Coolant flush onto covers  
(Photo with opt. pump Grundfos MTH4-40/4)

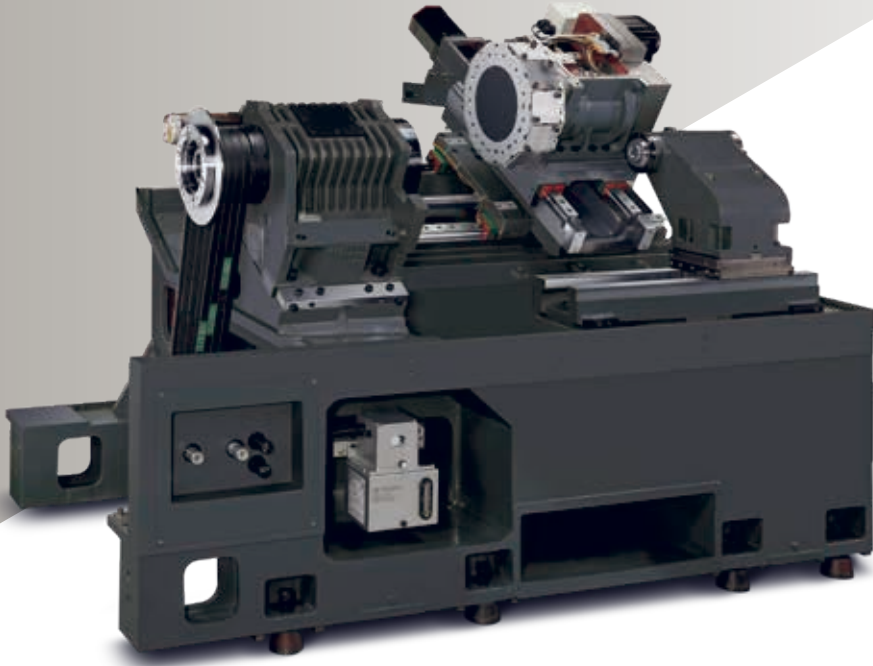

## C-axis Turn Mill (opt.)

- Belt-driven spindle with magnetic speed sensor as position coder to ensure accuracy 0.01°.
- Milling motor by servo motor with spindle control (G96.4) for easy programming with Manual Guide I.
- Milling turret by BMT (bolt mounted tooling) for high static rigidity.
- Milling speed 4000rpm (opt. 6000rpm with oil mist lubrication).

## Milling Motor Output (2.2 kW)

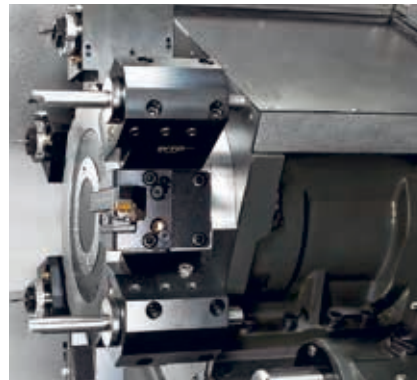
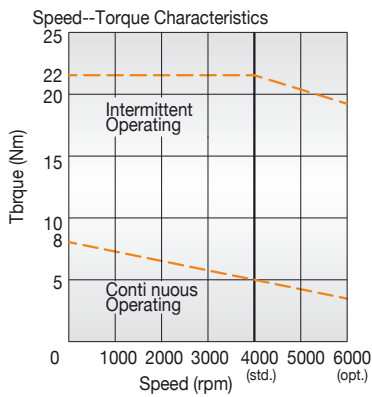

Manual MT#3 tailstock (opt.)

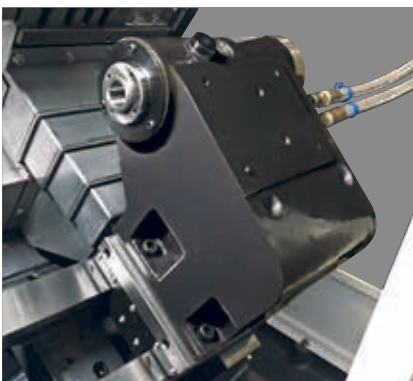

Tool Presetter & Part catcher (opt.)



Oil skimmer (opt.)

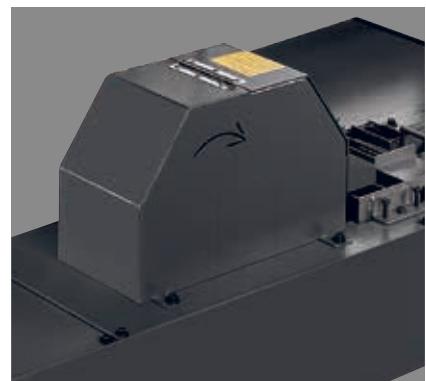

# Built for Unmanned Operation

## Built in articulated robot EWR-03

- Maximum part weight: 3 kg
- Maximum part size: Ø120 x L.100 mm
- Part loading/unloading time along chuck: 7 seconds.
- Slant-pallet work feeder for easy orientation and high flexibility.



Robot with grippers

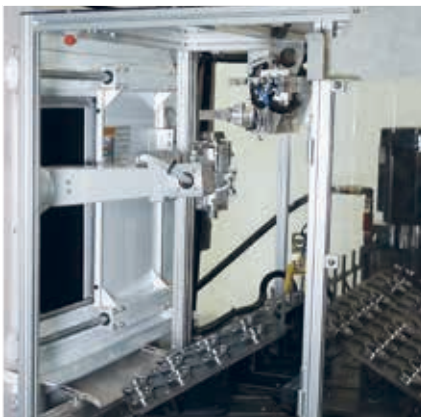
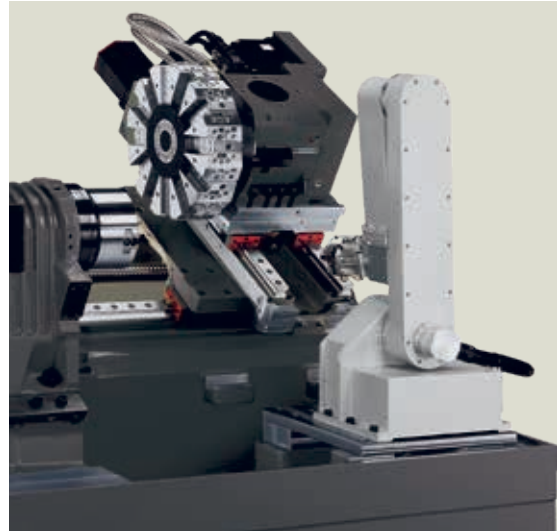

Work feeder (multiple pallets) and Turnover station

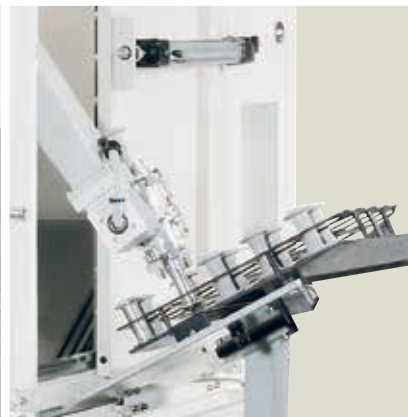

Work feeder (single pallet)



Work feeder (vibrator)

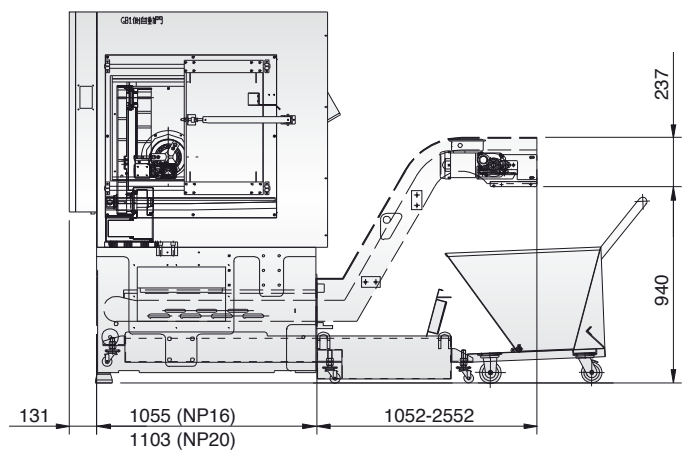
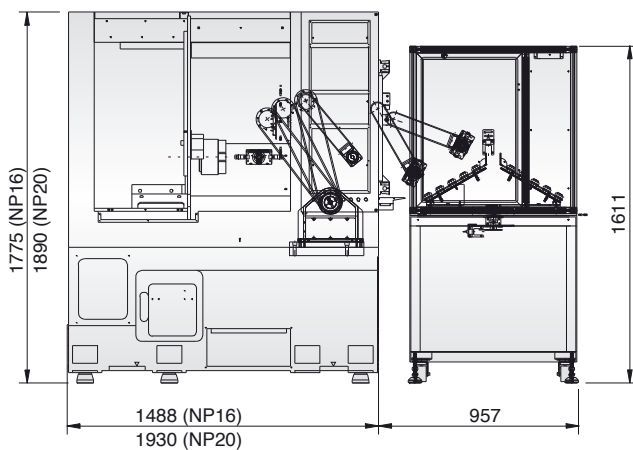

# Gantry Robot

- Mounted on machine base composes a compact cell
- Heavier parts (> 3 kg) can be loaded
- Part changeover time: 15 seconds (including door open/close time)
- One robot can take care two lathes.
- Measuring station can be integrated for on-line inspection.



Work feeder (piled up type)



Work feeder (flexible)



Turnover station

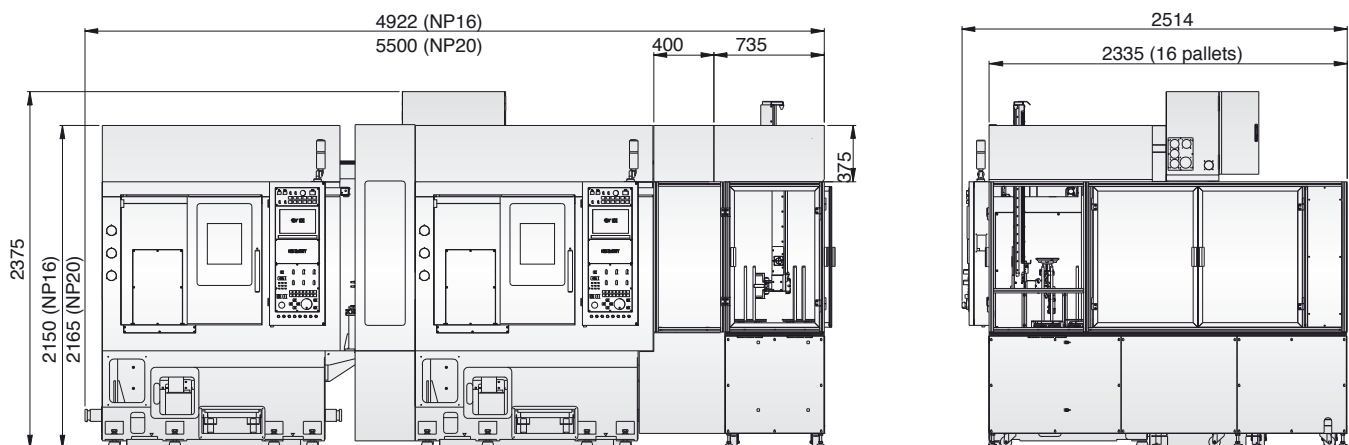



# VICTOR Taichung's FANUC Oi-TF 10.4'' Control (Type I) Specifications



## Standard

ITEM/SPECIFICATION	DESCRIPTION
<b>Controlled Axes</b>	
1. Controlled axes	2 Axes (X, Z)
2. Simultaneous controlled axes	2 Axes
3. Least input increment	0.001mm
4. Least command increment	0.0005mm (X) / 0.001mm (Z)
5. Command system	Incremental / Absolute
6. HRV Control	HRV3+
7. Unexpected disturbance torque detection (AIR-BAG)	Std.
8. Backlash compensation	Std.
9. Stored pitch error compensation	Std.
<b>Operation &amp; Program Input</b>	
1. Input / Output interface	RS-232, PCMCIA Card, USB
2. Tool offset	99 sets
3. Sequence number	N5-digit
4. Program number	O8-digit
5. Program name	31-characters
6. M code function	M3-digit
7. S code function	S4-digit
8. T code function	T4-digit
9. Positioning	G00
10. Linear interpolation	G01
11. Circular interpolation	G02, G03
12. Programmable data input	G10
13. Plane selection	G17-G19
14. Inch / Metric conversion	G20 / G21
15. Reference position return	G28, G30
16. Thread cutting	G32, G34
17. Threading retract	Std.
18. Tool nose radius compensation	G40-G42
19. Work piece coordinate system	G52-G59
20. Macro, Sub program call	G65, M98, M99 (10 folds nested)
21. Multiple repetitive cycle I & II	G70-G76
22. Canned cycle for drilling	G80-G89
23. Canned cycles	G90, G92, G94
24. Program stop / end	M00-M02 / M30
25. Rigid tapping (Spindle)	M29
26. Manual Guide I	Std.
27. Optional blocks skip 2-9	Std.

## Feed Function

1. Manual handle feed rate	X1, X10, X100
2. Rapid traverse rate	F0, 25%, 50%, 100%
3. Cutting feed rate	0-150%
4. Spindle override	50-120%
5. Feed per Minute / Revolution	G98 / G99

## Edit Operation

1. Part Program Storage Length (in total)	1280m / 512kB (Oi / 32iB)
2. Number of Registerable programs (in total)	400.
3. Part Program Editing	Std.

## C Axis Function

1. Polar coordinate interpolation	G112, G113
2. Cylindrical interpolation	G107
3. CS contouring control	Std.
4. Spindle control with servo motor	G96.4
5. Coordinate System Rotation	Std.

## OPTIONS

### With hardware included

	OI-TF
1. Tool life management	<input type="checkbox"/>
2. Program restart	<input type="checkbox"/>
3. Data server (with PCB and ATA card)	<input type="checkbox"/>
4. Fast Ethernet (100Mbps, available in Data server)	<input type="checkbox"/>
5. CC Link (included Robot)	<input type="checkbox"/>
6. PROFIBUS slave	<input type="checkbox"/>

### Without hardware included

7. Part program storage length (5120m/2MB)	<input type="checkbox"/>
8. Number of registerable programs 1000	<input type="checkbox"/>
9. Circular thread cutting (G35,G36)	<input type="checkbox"/>
10. AICC-1 (G5.1 Q1, 40 blocks)	<input type="checkbox"/>
11. AICC-2 (G5.1 Q1, 200 blocks)	<input type="checkbox"/>
12. Helical interpolation (C-axis only)	<input type="checkbox"/>
13. Arbitrary speed threading	<input type="checkbox"/>

## NP20 Bigger Spindle Output (18.5 kW, S3-15%, optional)

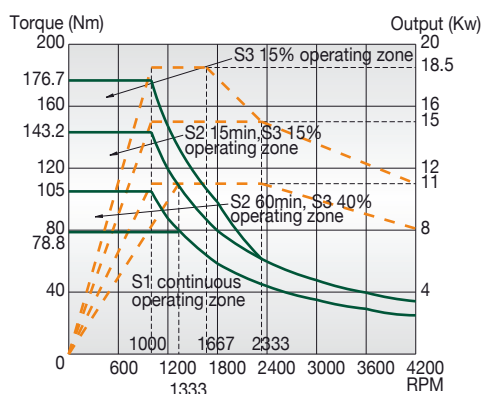

## Machine Color Option



Standard



RAL-7024

# Interference Chart / Operating Range

## Vturn-NP16

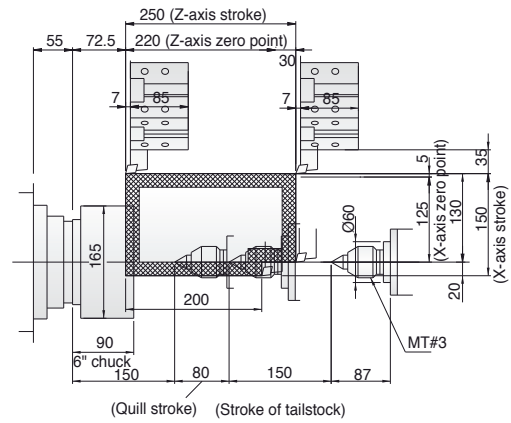
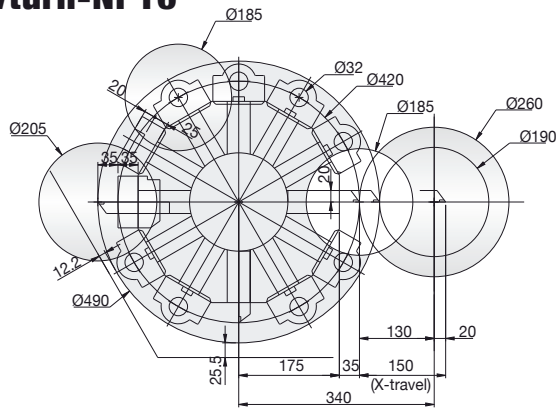

## Vturn-NP16CM

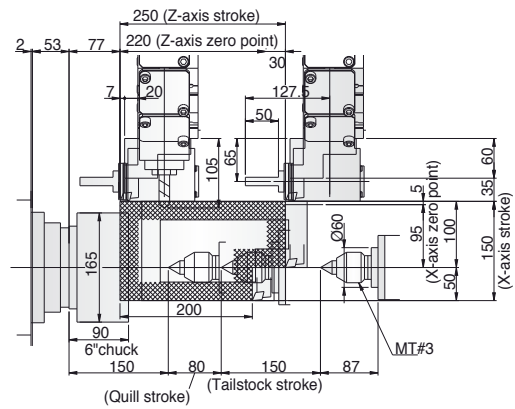
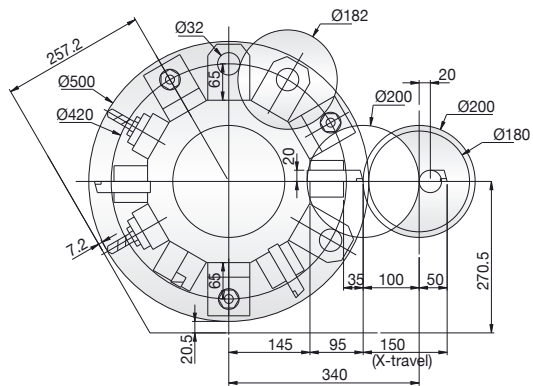

## Vturn-NP20

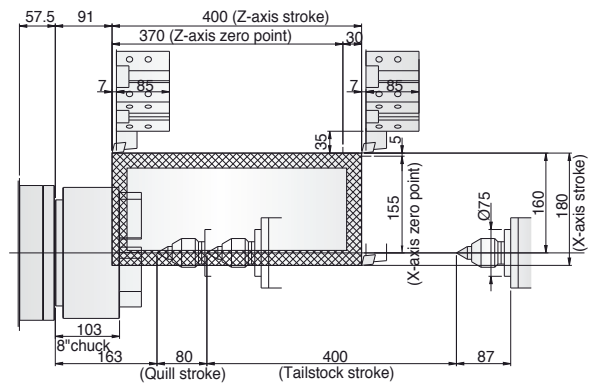
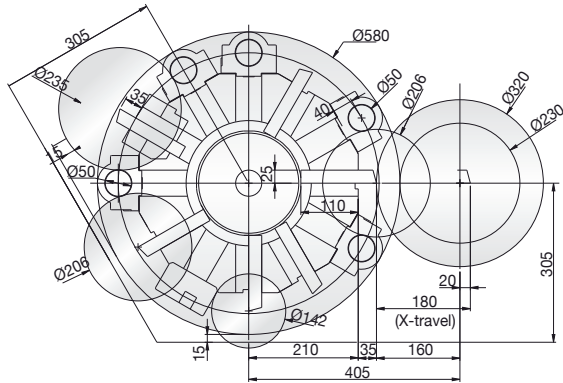

## Vturn-NP20CM

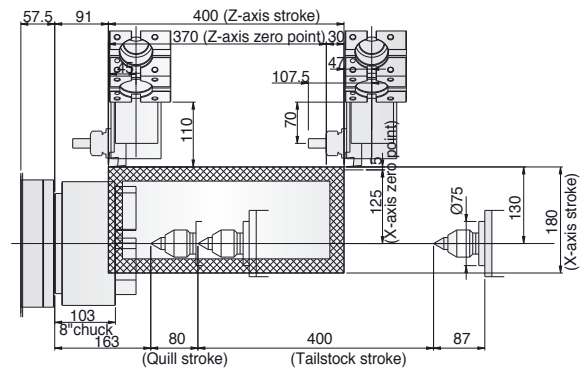
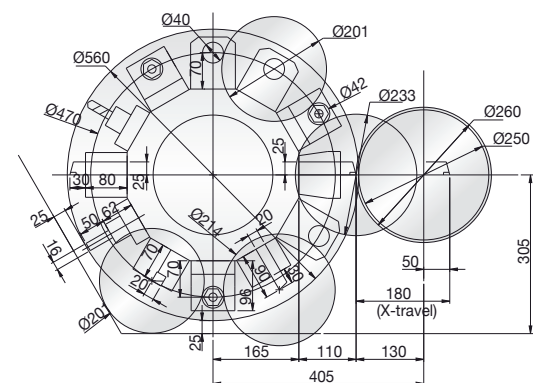

# Machine Layout



## Vturn-NP16

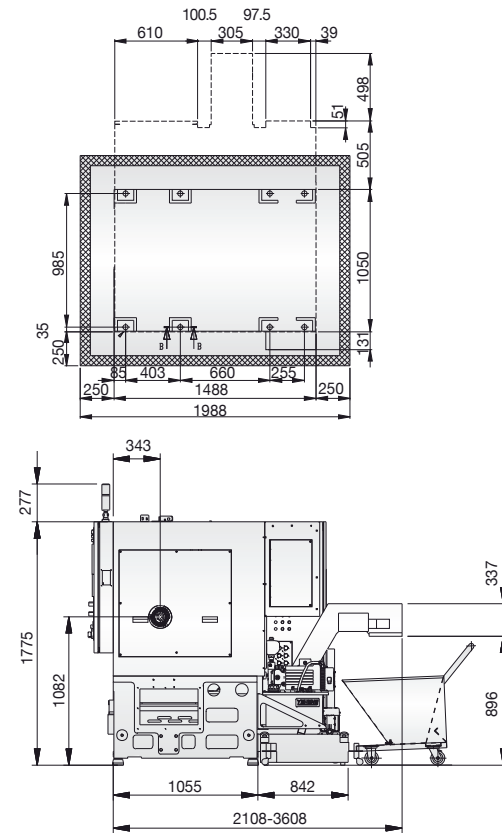
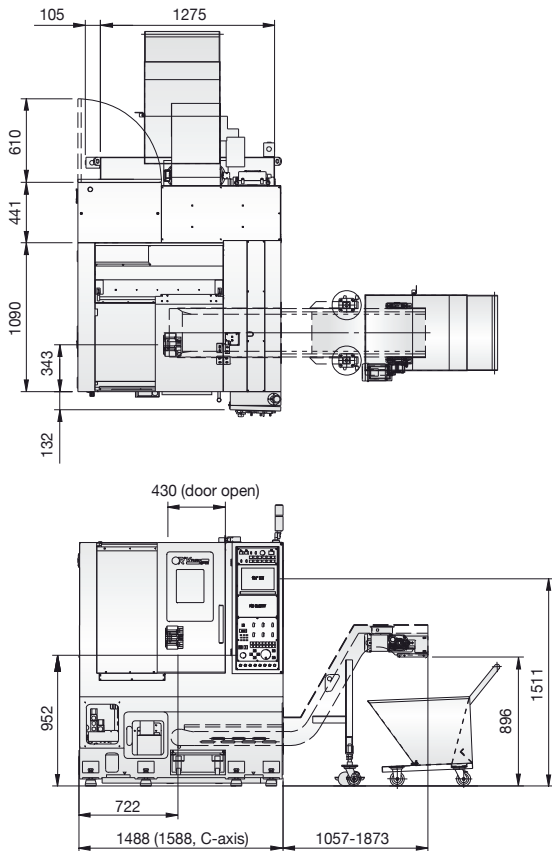

## Vturn-NP20

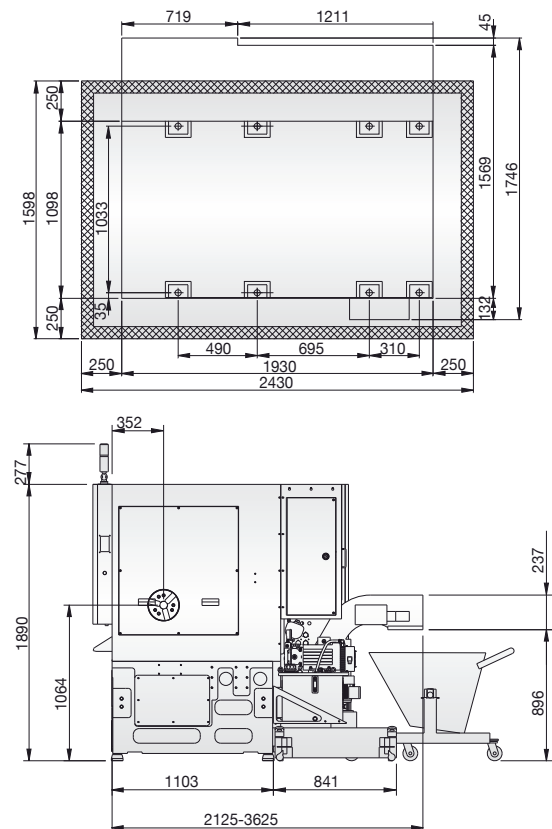
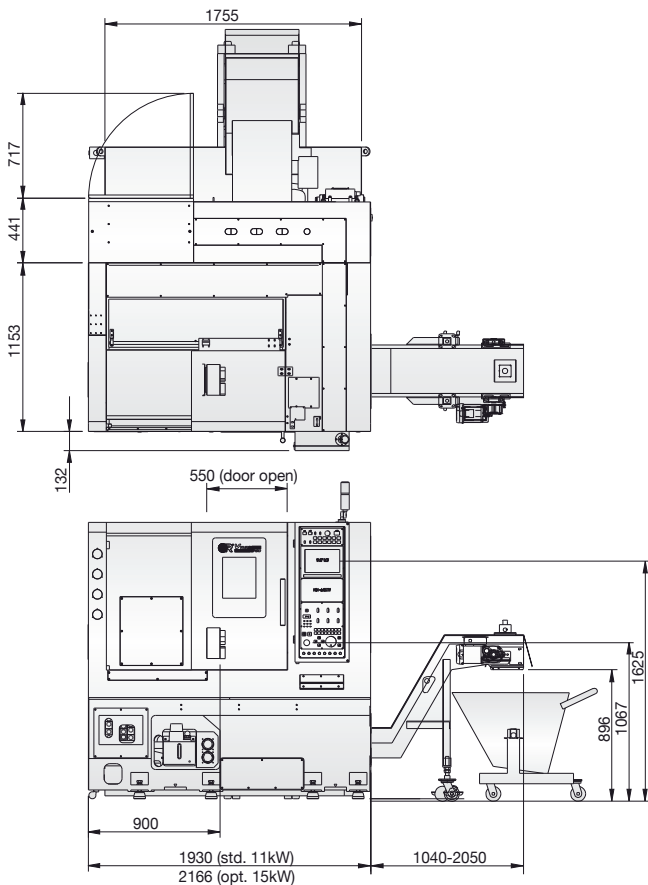

# Machine Specifications

Item	Unit	Vturn-NP16 (CM)	Vturn-NP20 (CM)
<b>Capacity</b>			
Swing over bed dia.	mm	Ø570	Ø650
Standard turning dia.	mm	Ø185 (Ø200)	Ø206 (Ø234)
Maximum turning dia.	mm	Ø260 (Ø200)	Ø320 (Ø260)
Swing over carriage dia.	mm	Ø325	Ø365
Between centers	mm	270	520
Bar capacity (Hole thru draw bar)	mm	Ø42	Ø52
<b>Axis Feeds</b>			
X axis travel	mm	20+130 (50+100)	20+160 (50+130)
Z axis travel	mm	250	400
Rapid feed - X / Z axis	m/min	30 / 30	30 / 30
Feed motor - X / Z axis	kW	1.8 / 1.8	1.8 / 1.8
JOG feed	mm/min	X/Z: 0~1260	X/Z: 0~1260
Ball screw dia. x pitch	mm	Ø25 x P10 (X) Ø40 x P10 (Z)	Ø25 x P10 (X) Ø40 x P10 (Z)
Guideway width - X / Z axis	mm	35 / 35	35 / 35
<b>Spindle</b>			
Spindle speed	rpm	6000	4200
Spindle nose (chuck)	inch	A2-5 (6")	A2-6 (8")
Spindle motor power (cont./30min/25%)	kW	5.5 / 7.5 / 11	7.5 / 11 / 15 (opt. 11 / 15 / 18.5)
Spindle bearing inside dia.	mm	Ø80	Ø100
Spindle taper		1/20	1/20
<b>Turret</b>			
No. of tools (live)		12 (12)	12 (12)
Tool shank size	mm	□20	□25
Max. boring bar dia.	mm	Ø32 (BMT-45)	Ø40 (BMT-55)
Exchange time (T-T)	sec	0.9 (opposite)	0.9 (opposite)
Milling speed	rpm	4000 (opt. 6000)	4000 (opt. 6000)
Milling motor	kW	2.2	2.2
<b>Tailstock (Optional)</b>			
Tailstock quill dia.	mm	Ø60	Ø75
Quill stroke	mm	80	80
Quill taper		M.T. #3	M.T. #4
<b>Machine</b>			
NC controller	Fanuc	Oi-TF (10.4")	Oi-TF (10.4")
Coolant tank capacity	L	160	240
Power requirement	kVA	14.4 (15.1)	16.6 (17.3)
Machine dimension L x W x H	mm	1488 (1588) x 2108 x 1775	1930 x 2125 x 1890
Net weight (incl. standard accessories)	kgs	3700 (4070)	4000 (4370)

\* Machine and controller specifications are subject to change without notice.

## Standard accessories:

- Fanuc Oi-TF (10.4") with Manual Guide i
- Hydraulic chuck with soft jaws
- Chip conveyor (rear disposal)
- Fully enclosed splash guarding
- Tool holders (only for standard turret)
- Coolant flush on Z-axis cover
- 3 step warning light

## Optional accessories:

- Manual tailstock with power quill
- Chip conveyor (right disposal)
- Manual tool presetter
- Auto tool presetter
- Parts catcher (swing type)
- KITAGAWA® power chuck
- Air conditioner for electrical cabinet (Panel cooler)
- Higher pressure coolants
- Bar feeder interface
- Air blow
- Oil skimmer
- Oil mist collector
- Hard jaws
- Tailstock center
- Auto door
- Separable chip conveyor (to save floor space when drawn out)
- C-axis
- Robot system



THE VICTOR-TAICHUNG COMPANIES

### TAIWAN

http : //www.victortaichung.com  
E-mail : info@mail.or.com.tw

- Victor Taichung Machinery Works Co., Ltd.

### Headquarters:

2088, Sec. 4, Taiwan Blvd.,  
Taichung, Taiwan, R.O.C.  
TEL : 886-4-23592101  
FAX : 886-4-23592943

### Overseas Marketing Division:

TEL : 886-4-23580701  
FAX : 886-4-23584541

### UK

- Victor CNC (UK) Ltd.  
TEL : 44-1-706-648485  
FAX : 44-1-706-648483

### FRANCE

- Victor France  
TEL : 33-1-64772000  
FAX : 33-1-64772063

### GERMANY

- Victor GmbH  
TEL : 49-2261-478434  
FAX : 49-2261-478327

### MALAYSIA

- Victor Machinery (M) SDN. BHD.  
TEL : 60-3-56337180  
FAX : 60-3-56337191

### THAILAND

- Victor (Thailand) Co. Ltd.  
TEL : 66-2-9263735  
FAX : 66-2-9032373

### INDONESIA

- PT. Victor Machinery Indonesia  
TEL : +62-21-88958504  
FAX : +62-21-88958513

### USA

- Fortune International Inc.  
TEL : 1-732-2140700  
FAX : 1-732-2140701

### SOUTH AFRICA

- Victor Fortune (PTY) Ltd.  
TEL : 27-11-3923800  
FAX : 27-11-3923899

### CHINA

- Victor Taichung Machinery (Shanghai)  
TEL : 86-21-59768018  
FAX : 86-21-59768009



HTL

VTL

VMC

HMC

XMT

PIM

**Victor Taichung profile:**  
Sales turnover: USD 145 mil's (in 2018)\*  
No. of employees: 836  
\*Exchange rate: 1 USD=30 TWD.

